

THE CENTER FOR **UNIVERSAL DESIGN**
North Carolina State University
College of Design
Box 8613
Raleigh, NC 27695-8613

919.515.3082 (voice and TTY)
919.515.3023 (FAX)
800.647.6777 (V/TTY Info Request Line)
cud@ncsu.edu

Affordable and Universal Homes

Affordable and Universal Homes

Affordable and Universal Homes

Affordable and Universal Homes

NC STATE UNIVERSITY

A Plan Book

SUPPLIED BY:
CAROLINA BUILDERS



Affordable and Universal Homes

Affordable and Universal Homes

A Plan Book

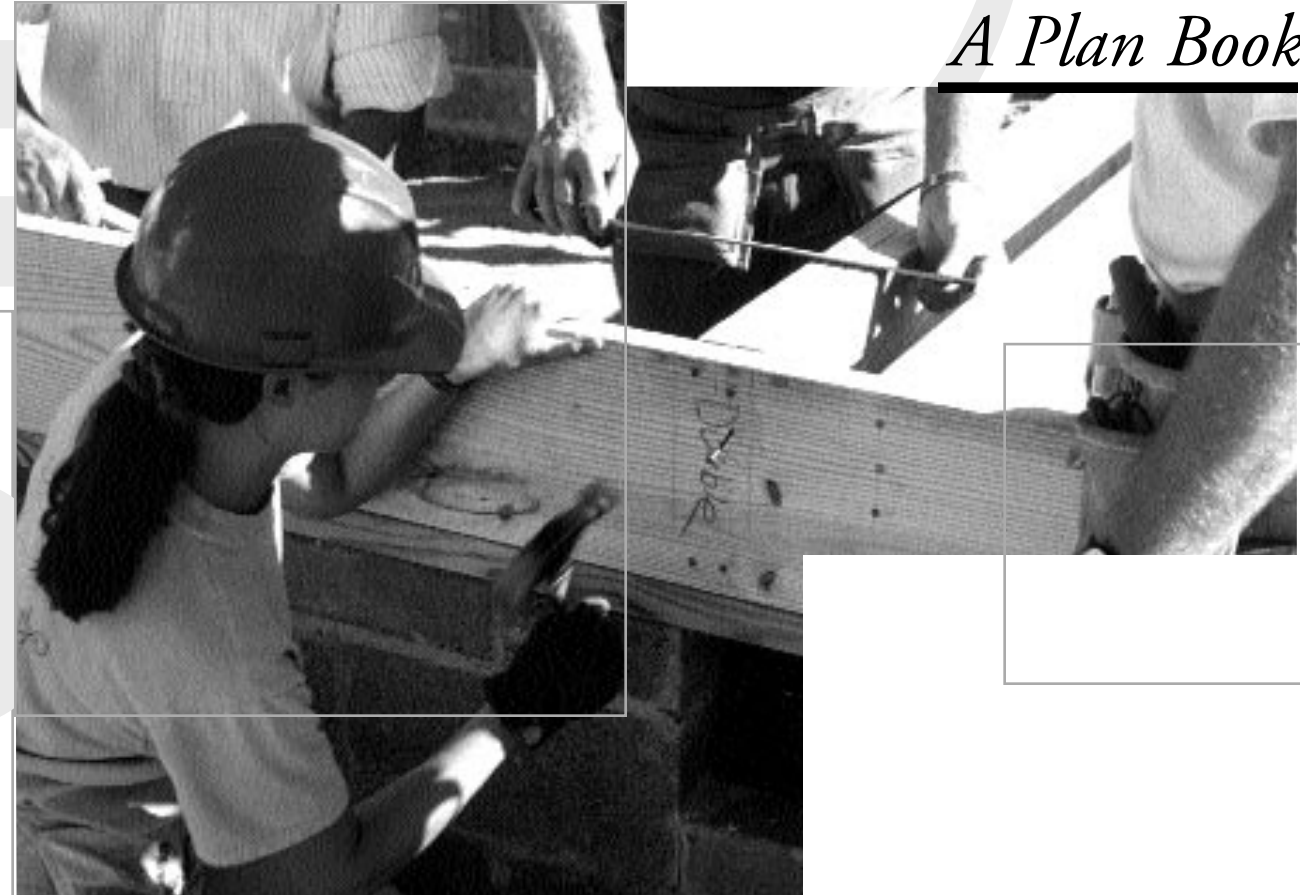

Funding for Affordable and Universal Homes from the Ability II program of the Kate B. Reynolds Charitable Trust

Major funding for the Center for Universal Design is provided by the National Institute on Disability and Rehabilitation Research, United States Department of Education

The Center for Universal Design
College of Design
North Carolina State University

Project Acknowledgments

The Center for Universal Design
College of Design
North Carolina State University
219 Oberlin Road
Box 8613
Raleigh, North Carolina 27695-8613

Richard Duncan, Project Director
Rex Pace, Project and Design Manager
Charles Faust, Project Assistant
Robert Phinney, Project Assistant

Ability II Program

David Yoder, Project Director
Maggie Sauer, Project Administrator

Kate B. Reynolds Charitable Trust

John Frank, Director
Health Care Division

Orange County Habitat for Humanity

Susan Levy, Executive Director
John C. Clark, Jr., Construction Coordinator
Tyler Momsen-Hudson, Construction Supervisor
Anne-Marie Vanaman, Development Director

Chatham County Habitat for Humanity

Amy Powell, Executive Director
Andrew Wright, Construction Manager
Jim Cochran, Construction Committee

Without support, good ideas and worthy projects lie fallow. Many thanks to the Kate B. Reynolds Charitable Trust and the Ability II Program for funding this initiative.

We are extremely grateful to the leadership and staff at Orange County Habitat for Humanity and Chatham County Habitat for Humanity. Their vision and persistence has made universal housing a reality for their homeowners. However, one person deserves special recognition. It is rare to find a collaborator with enthusiasm, expertise, an open mind, and creativity. John Clark quickly understood universal design and was able to translate it into a plan actionable by a Habitat affiliate with cost and space constraints and volunteer labor. John Clark has our enduring respect and gratitude for his work on Affordable and Universal Homes for Independence.

Publication Credits

Concept and Development
Contributing Editor
Design and Production
Production Assistance
Illustration and Drafting

Richard Duncan and Rex Pace
Leslie Young
Robert Rock
Denee Black, Danny Vinson
Charles Faust, Rex Pace,
Robert Phinney

Portions adapted from "Universal Design: Housing for the Lifespan of all People," The Center for Universal Design, 1988. Portions also adapted and excerpted from other currently unpublished center work.

© 2000, NCSU, Center for Universal Design

Table of

Contents

vii

9

10

17

24

Universal Design...



makes things easier to use



benefits all ages



adds convenience



accounts for differing abilities

Introduction

In recent years, it has become apparent and more widely recognized that home design needs to address a dynamic range of people and abilities. Housing in this century must be able to adapt to the differing needs and requirements of the users, no matter their age or strength or agility. This design approach, known as universal design, strives to make the day-to-day home living and home tasks possible and safer for everyone. These goals are no less significant for affordable housing and, in fact, may even be more critical for households that lack the financial and social resources to effectively deal with dramatic life changes from sickness and injury, effects of aging, or support other family members affected by these issues. The ability to be physically independent is a critical part of being financially independent.

The continuing problem of decent affordable housing for low-income households is compounded by the availability of few homes that respond to the diverse needs of individuals with disabilities and others. For these households, finding decent, affordable housing that also supports their activities is extremely difficult. Moreover, households living in typical homes with a disabled family member often face expensive modifications that they can not afford such as ramps, wider doorways, or usable bathrooms. Housing that supports occupants with a disability now, and which doesn't require expensive modifications later is clearly superior to standard homes. For housing to adequately address these needs all home design must recognize and accept that being human means that there is no one-model individual whose characteristics remain static through their lifetime. Universal design embodies this inclusive spirit.

Affordable and Universal Homes for Independence

To help with this housing problem The Center for Universal Design (CUD) created a two-year design, product selection, and construction program with local Habitat for Humanity affiliates to help produce affordable, universally designed homes. In this project, the center reviewed and, in consultation with two local North Carolina Habitat affiliates (Chatham and Orange counties) and

consumers, revised their standard house plans, converting them to accommodate households with a disabled family member without sacrificing cost or appearance. This has enabled Habitat to create universal homes for all their households, even those that do not currently have a disabled family member. Habitat has generated a long-term benefit for families by helping them avoid costly renovations should a family member develop a particular need for accessible features in the future.

The Center's activities divided into three phases. During Phase 1 staff produced revised floor plans and worked with Habitat on site selection and site preparation to enhance access to the homes. For homes to be universal, the products and materials in them must be as usable as the design. The Center's Phase 2 work was appliance and product selection, ensuring universal, yet low-cost choices. Center staff selected the most affordable, most universally usable products for homes including appliances, plumbing fixtures, controls, hand railings, and lighting fixtures. The project contributed \$45,000 for products and building materials and resulted in 16 homes with universal features. During Phase 3, staff monitored the construction progress of the homes to ensure that the universal plans turned into universal homes. We evaluated the newly built homes for their universal features as well as interviewed homeowners for their perception of the usefulness of the features.

Affordable and Universal Homes for Independence (UHI) demonstrated that Habitat can produce universal and affordable homes. Through this publication and other demonstration projects, we will promote these new design standards to other Habitat affiliates and affordable housing builders.

Affordable and Universal Homes: A Plan Book

This book is designed to be used by Habitat for Humanity affiliates to create universal homes. The book features five plans, some of which have been adapted from existing plans used by our affiliates, and some of which were newly created. We have also included a brief introduction to universal design and an outline of the universal features to consider. We hope that affiliates will adapt and use these plans as they can.

What are Universal Housing Features?

Universal homes look and function as ordinary homes but are easier to use, safer, and more convenient. When incorporated during design, universal features cost little but can save money later. Universal housing features are any component of a house that can be used by everyone regardless of their level of ability or disability. Such features make day-to-day activities easier for many and possible for some. Universal design is an approach to design that incorporates products as well as building features and elements which, to the greatest extent possible, can be used by people of all ages, sizes, and abilities.

Universal features are generally standard building products or features that have been placed differently, selected carefully, or omitted. For example, standard electrical receptacles can be placed higher than usual above the floor, and standard but wider doors can be selected. Moving day is less arduous in a house with a stepless entrance and wider doors and hallways. This same entrance allows a person with a mobility aid to visit a friend and participate in the larger community. Examples of other universal features in housing are:

- handles for doors and drawers that require no gripping or twisting to operate—such as lever or loop handles;
- appliances that are easy and safe to use; and
- storage space within reach of both short and tall people.

Many universal features are no cost options. Others are low-cost solutions that can become no cost with widespread use. In our society, mass production is used to keep costs low and to produce products that are widely marketable. Because universally designed products make as little as possible “special,” and make as much as possible “standard,” mass producing design that is both usable and attractive to everyone can become a practical reality.

Much of universal design can be accomplished using conventional construction methods with standard building products. However there are three important construction issues that require a modified, but not necessarily difficult, approach. These are covered in the following section, *Key Construction Issues*.

The images on the opposing page and below show a few of the universal design features included in the homes built by the *Affordable and Universal Homes for Independence project*. Each image has a brief description explaining the benefit of the feature. For a more comprehensive overview, refer to the Universal Design Features listing at the end of this publication, page 24.

Cabinets with drawers and shelves on full-extension pull-out hardware allow contents to be seen and reached easily. Loop Hardware require no gripping or twisting to operate.



Front-loading washer and dryer with front mounted controls raised on a platform to minimize bending and stooping and place items inside the appliances within easier reach.



Side-by-side refrigerator places more freezer in the reach range of seated users.



Pressure balanced anti-scald lever control valve in offset location improves usability and safety.



Front-mounted controls on range prevents a person from reaching across burners and are easier to use from a seated position. Stove door handle is easy to grip.



Sidelight next to entry door allows full view of visitors from any height whether tall or short or standing or seated.



Key Construction Issues

Along with adequate space for maneuvering around the house, stepless entrances, bathroom blocking, and adaptable cabinets make big contributions to a universally usable house. These three important universal construction features in homes are reviewed in the following section.



Conventional construction with steps

Stepless Entrances

To achieve stepless entrances some unconventional, although not necessarily difficult, construction details may be required. With a crawl space foundation, creative landscaping can be an effective way to resolve differences in elevation between the exterior grade and interior floor level. Using soil from foundation excavation or having additional soil brought onto the site allows the creation of an earth berm and bridge—a combination landscape and hardscape feature. This strategy uses soil pushed up against a new retaining wall leaving a “dry moat” just in front of the house foundation for drainage and air circulation. A bridge spans the moat from the gently sloping walk to the house entrance. Of course, a slab foundation makes a universal entrance much easier to achieve.

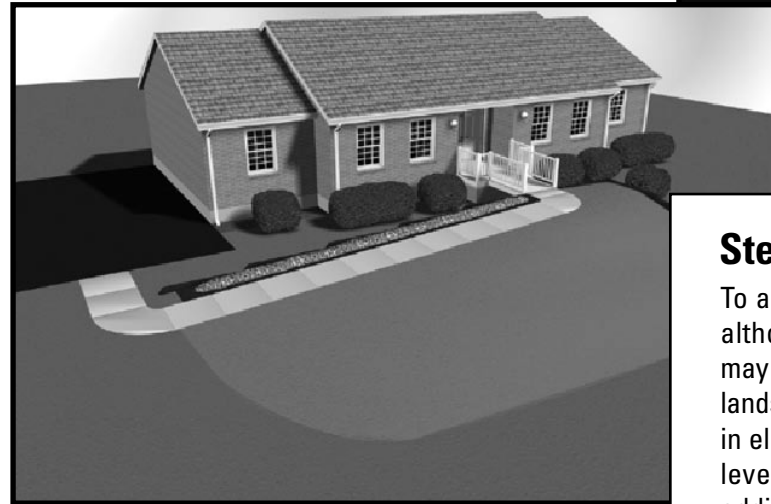

Earth berm and bridge used to achieve stepless entrance

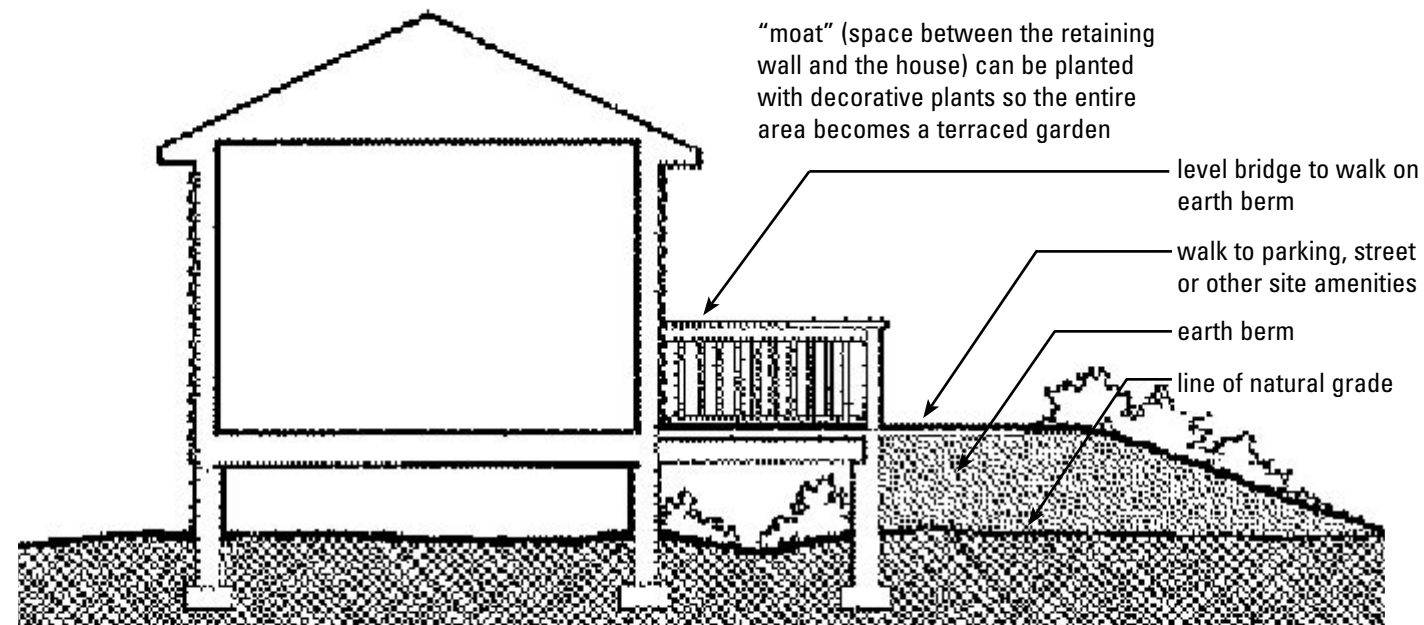

Bridges to Earth Berms on Flat Sites



Example of a Habitat house with a gently sloping walk on an earth berm and bridge to provide a stepless entrance.

When site conditions allow, the existing grade may be used to advantage. The length of an earth berm and bridge can be minimized by starting the route from parking at a “high” point on the site. It may even be possible to eliminate all slopes on a walk by extending a level bridge from a front porch or side entrance to an uphill point. With any strategy used, the relationship of parking to the house is critical and must be adequately addressed for an entrance to be truly universal.

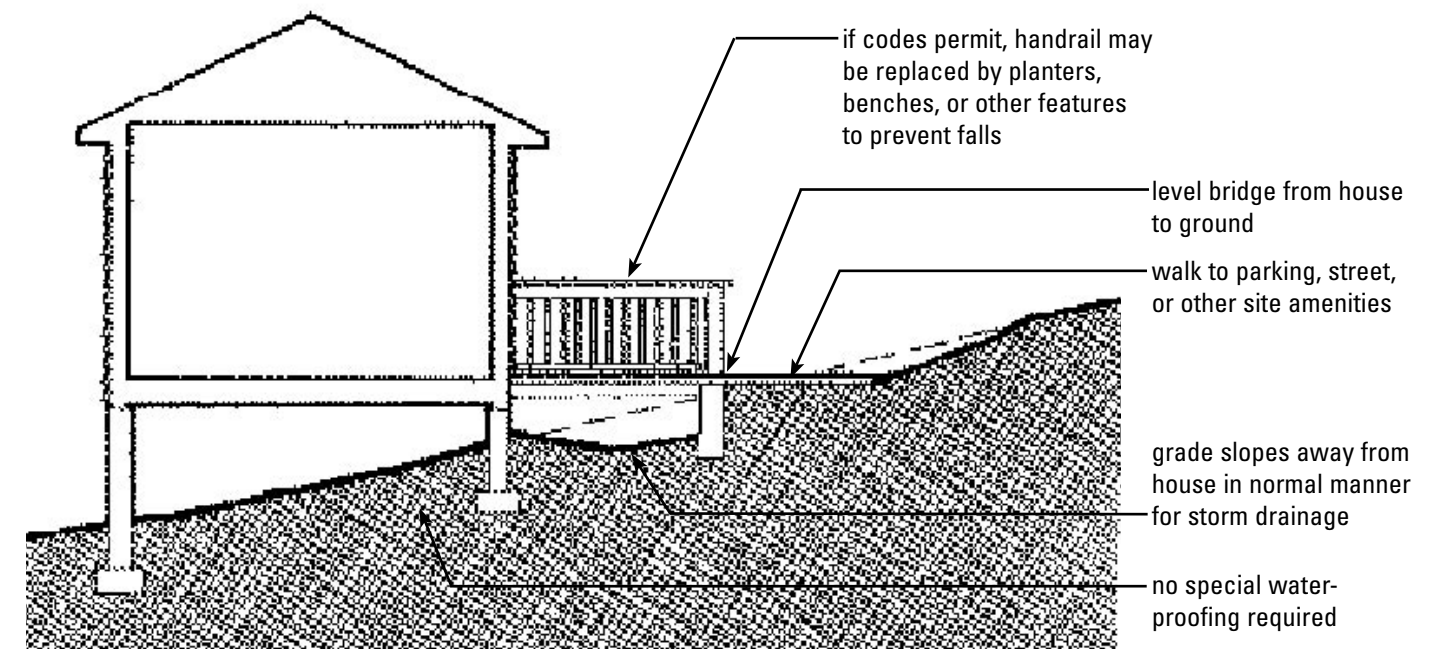

Bridges to Uphill Location on Sloping Sites

Key Construction Issues



Site placement of this Habitat house took advantage of the existing grade to achieve a gently sloping path on an earth berm at a side entrance.



Detail view of the example above where the side stoop has been incorporated as the "bridge" from the retaining wall to house.

Whole Wall Reinforcing

The addition of grab bars in bathrooms can greatly increase safety for everyone in an environment that is often slippery and wet. All walls around the toilet and bathing fixture should include reinforcing for the addition of grab bars, not only at the minimal positions as suggested in many design standards, but whole wall reinforcing. Grab bars do not necessarily have to be installed during initial construction, but can be added later when needed. Grab bars can then be confidently and securely screwed into place without tearing out the existing wall surface because the reinforcing is already installed.

Expanded whole wall areas of plywood reinforcing also allow more choices for grab bar placement at the best heights and configurations to suit individual needs. This is particularly helpful for many older people who desire vertical or angled grab bars for stepping in and out of bathing fixtures or getting up and down from toilet seats. Bars in these positions often fall outside of the required reinforced wall areas in national design guidelines and standards.

Providing onsite reinforcing for prefabricated bathing fixtures can be tricky. The backs of these molded fixtures often have uneven surfaces with many curbs and gaps that make it hard to evenly apply reinforcing in a consistent fashion. Additionally, there are often large areas where there are gaps between the fixture itself and the surrounding wall framing that make attaching the reinforcing to wood studs difficult. For these reasons it is best to buy fixtures with the reinforcing installed at the factory before it arrives onsite. Many manufacturers will install whole wall reinforcing when requested.



Whole wall reinforcing installed in a Habitat house

work around doors and windows as necessary

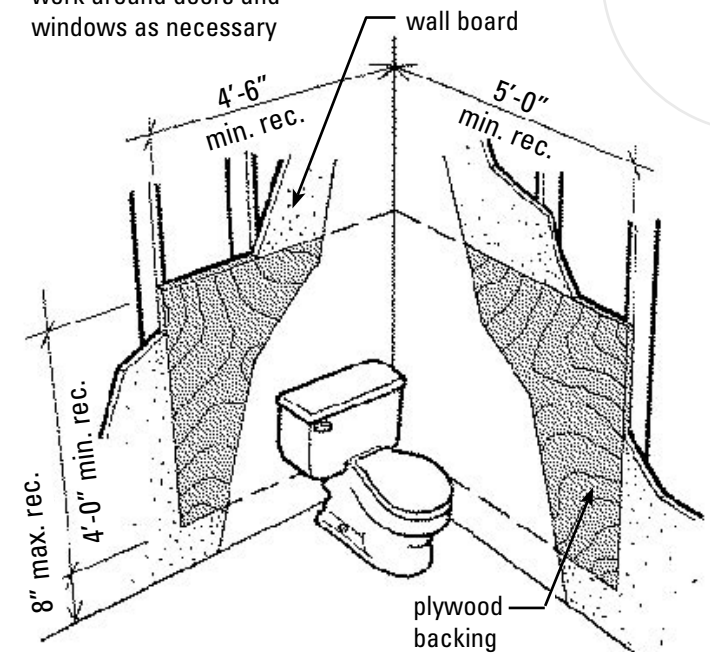

Whole Wall Reinforcing

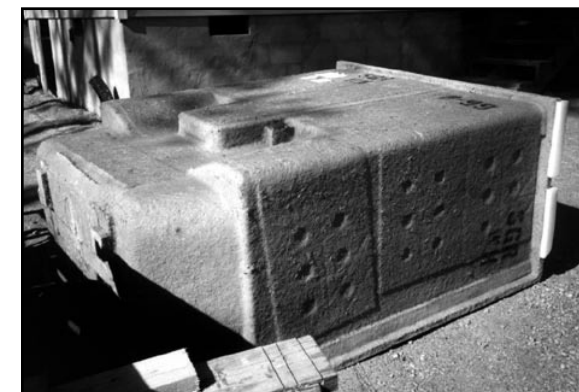

Back of molded bathtub fixture with uneven and irregular surfaces.



Back of molded shower fixture with whole wall reinforcing installed at factory.

Key Construction Issues

Adaptable Cabinets

The availability of knee space is necessary for many people. For people using wheelchairs the ability to pull up underneath kitchen sinks and bathroom lavatories is critical. Many older people and individuals with low stamina prefer or need to sit while performing tasks at these fixtures. Ideally, all homes would provide knee spaces at the time of initial construction to account for these possible present or future scenarios.

However, knee space has a dramatic impact on the appearance and functionality of kitchens and bathrooms. A uniform cabinet appearance is possible with a cabinet that easily can be reconfigured or removed to reveal knee space and still provide maximum storage. When a potential resident or owner needs the knee space, it can be

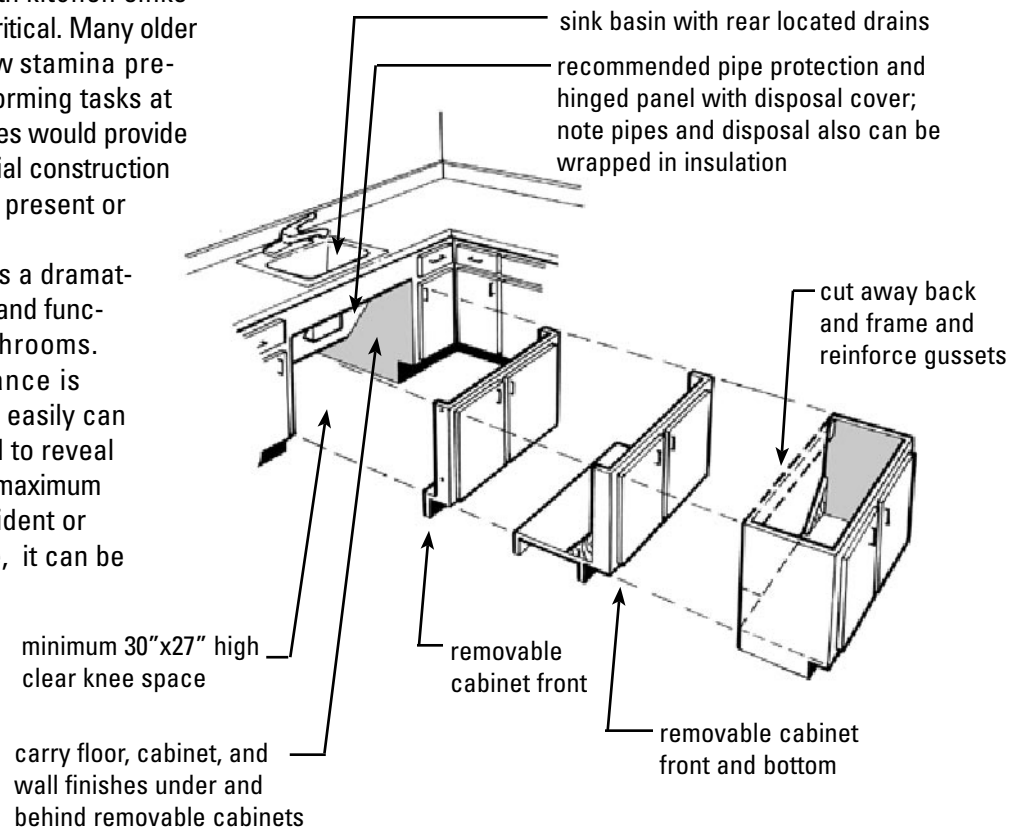

Removable Cabinet Options

There are no kitchen cabinet manufacturers that currently offer "removable base cabinets" in their standard lines. The methods for providing removable cabinets presented here are some of the possible solutions. However, when parts and elements are removed or detached they are more likely to be discarded and therefore not available if it becomes desirable to return the cabinet to its original appearance and function.

Use of swinging retractable cabinet door hardware provides another excellent method to conceal knee space because the doors are self-storing and no part of the cabinet must be removed or stored at another location. A unique combination hinge allows the doors to swing open in a traditional manner and, when desired, the doors may be pushed back into the cabinet.

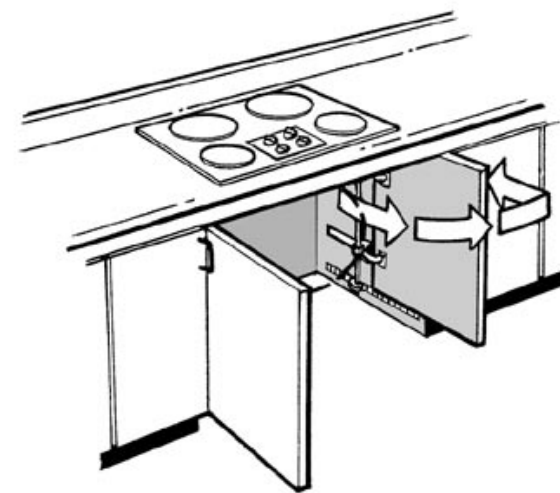

Use of swinging retractable cabinet door hardware to achieve a very easy to adapt base cabinet without removing any parts.



Swinging retractable cabinet door solution installed in a Habitat house during construction.

For knee space to be safe, usable, and aesthetically integrated the floor, walls, and cabinet faces of knee space must be finished during initial construction so no other work is necessary when the cabinet is adapted. Regardless of whether the knee space is exposed or concealed by a removable cabinet, hot pipes or exposed edges should be insulated or enclosed at the time of initial construction.

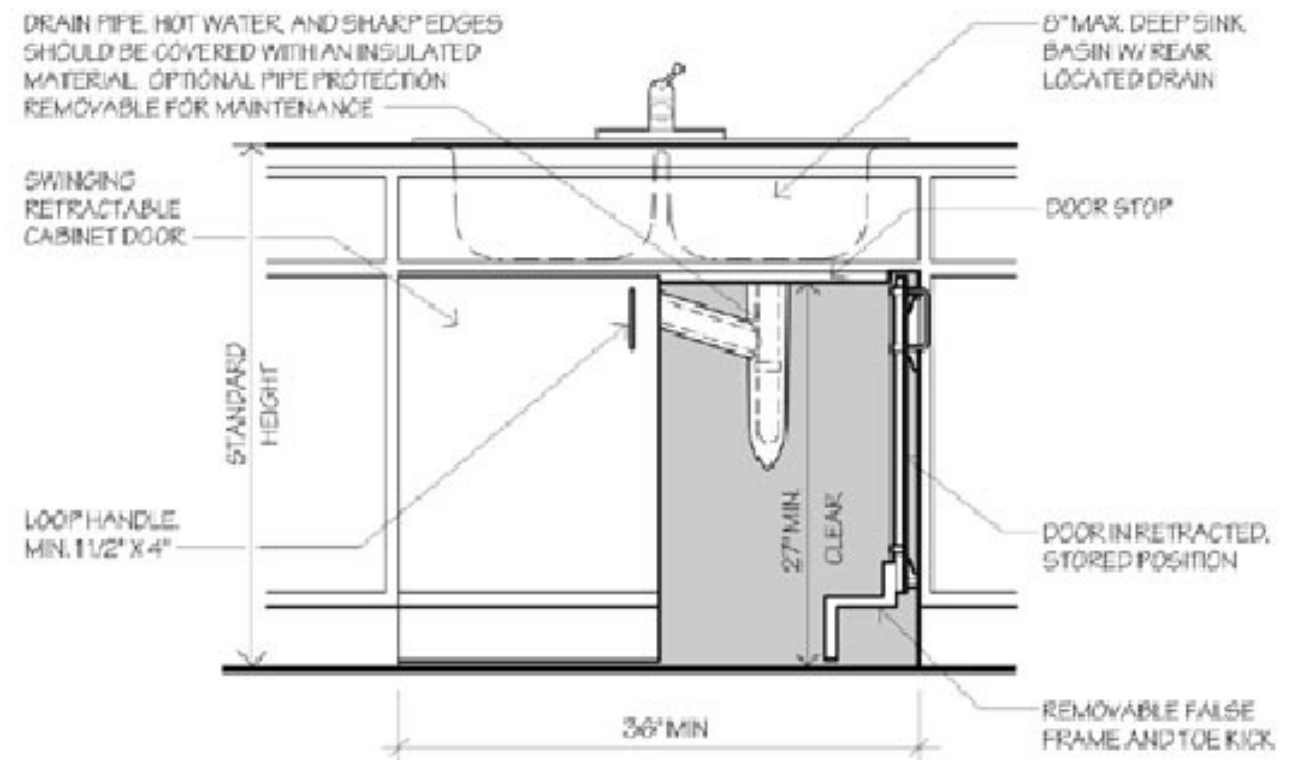

Cabinet Elevation Example

Key Construction Issues

In some small bathrooms, even with retractable doors, sufficient maneuvering space cannot be provided because the sidewall of the cabinet obstructs maneuvering and turns by people using wheelchairs or scooters. On those occasions, it may be necessary to install a removable vanity cabinet at the time of initial construction. The countertop must be mounted on the wall with support brackets, a cabinet fitted around it, and the floor and wall finished beneath it. A pipe protection and appearance panel should be installed between the wall support brackets.

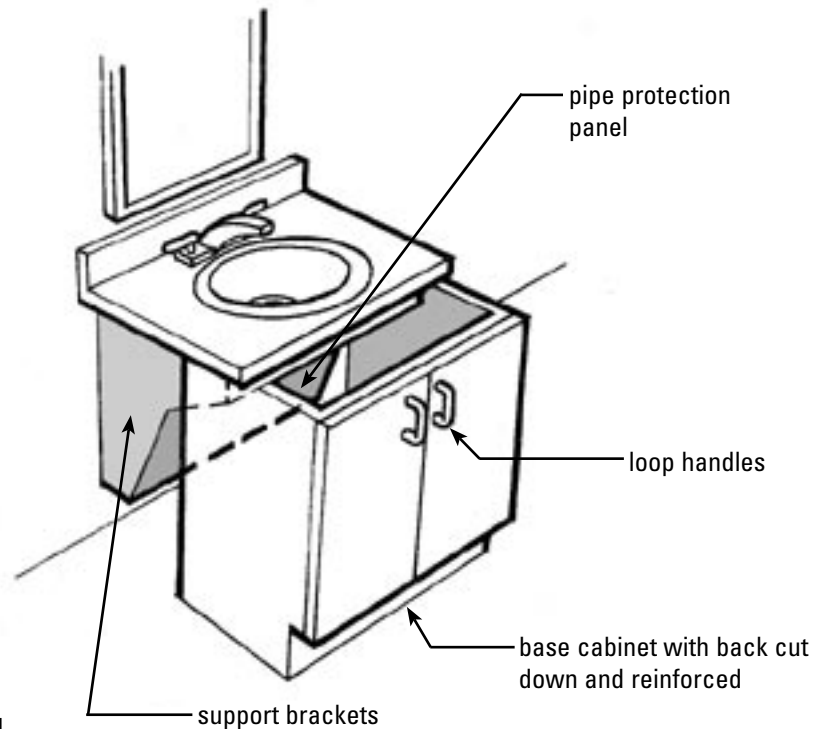

Removable Vanity Cabinet



The Floor Plans

The following section contains the floor plans developed from the Affordable and Universal Homes for Independence Project. Careful space planning and fixture/appliance placements combined with necessary maneuvering clearances, are reflected in the floor plans. The plans were developed to be as consistent as possible with each of the participating Habitat for Humanity affiliate's present design and construction practices.

All five floor plans were developed for actual construction projects. All the 3-bedroom plans and the 4-bedroom plan have been built. We encourage affiliates to incorporate parts of or entire plans into their construction programs.

Universal 2-Bedroom Plan

Universal 3-Bedroom Plan A

Universal 3-Bedroom Plan B

Universal 3-Bedroom Plan C

NOTES:

ROOM SIZES ARE APPROXIMATE.
 TOTAL AREA = 896 SQ.FT.
 TYP STUD WALL THICKNESS = 3-1/2"
 ALL PASSAGE DOORS ARE 3'-0"
 ALL OTHER DOORS 3'-0" WHEN POSSIBLE.
 ENTRY CONFIGURATION DEPENDS ON UNIQUE SITE CONDITIONS

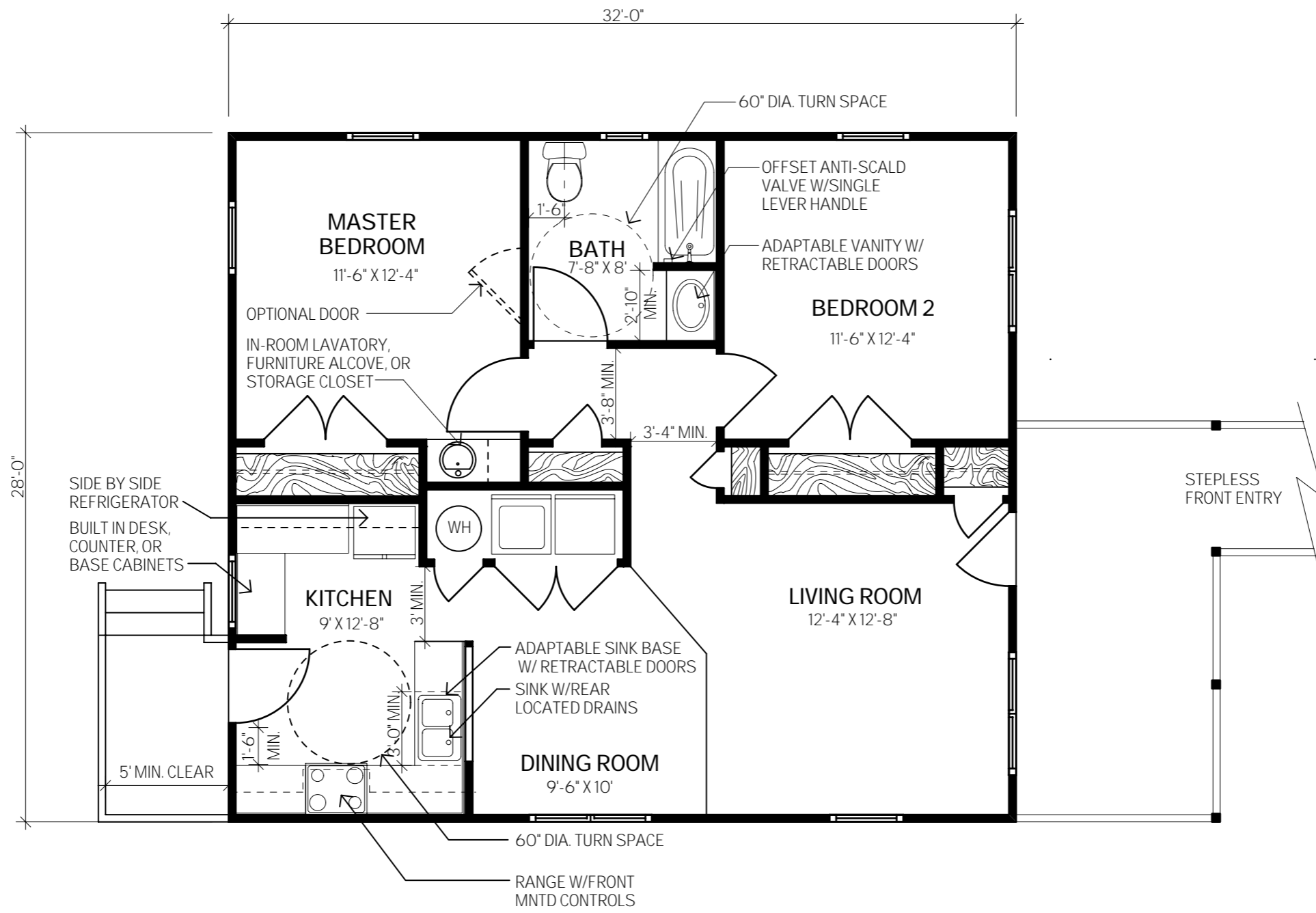

Disclaimer

These drawings are not for construction. If the information contained in these drawings is incorporated into any construction project, it shall be the responsibility of the owner, designer, or builder to comply with all applicable federal, state, and local codes, ordinances and regulations.

Title/Project: UNIVERSAL 2-BERROOM PLAN

Client: AFFORDABLE AND UNIVERSAL HOMES FOR INDEPENDENCE

Scale: 3/16" = 1'-0"

Date: 12/28/00

NOTES:

- ROOM SIZES ARE APPROXIMATE.
- TOTAL AREA = 1080 SQ.FT.
- TYP STUD WALL THICKNESS = 3-1/2"
- ALL PASSAGE DOORS ARE 3'-0"
- ALL OTHER DOORS 3'-0" WHEN POSSIBLE.
- ENTRY CONFIGURATION DEPENDS ON UNIQUE SITE CONDITIONS

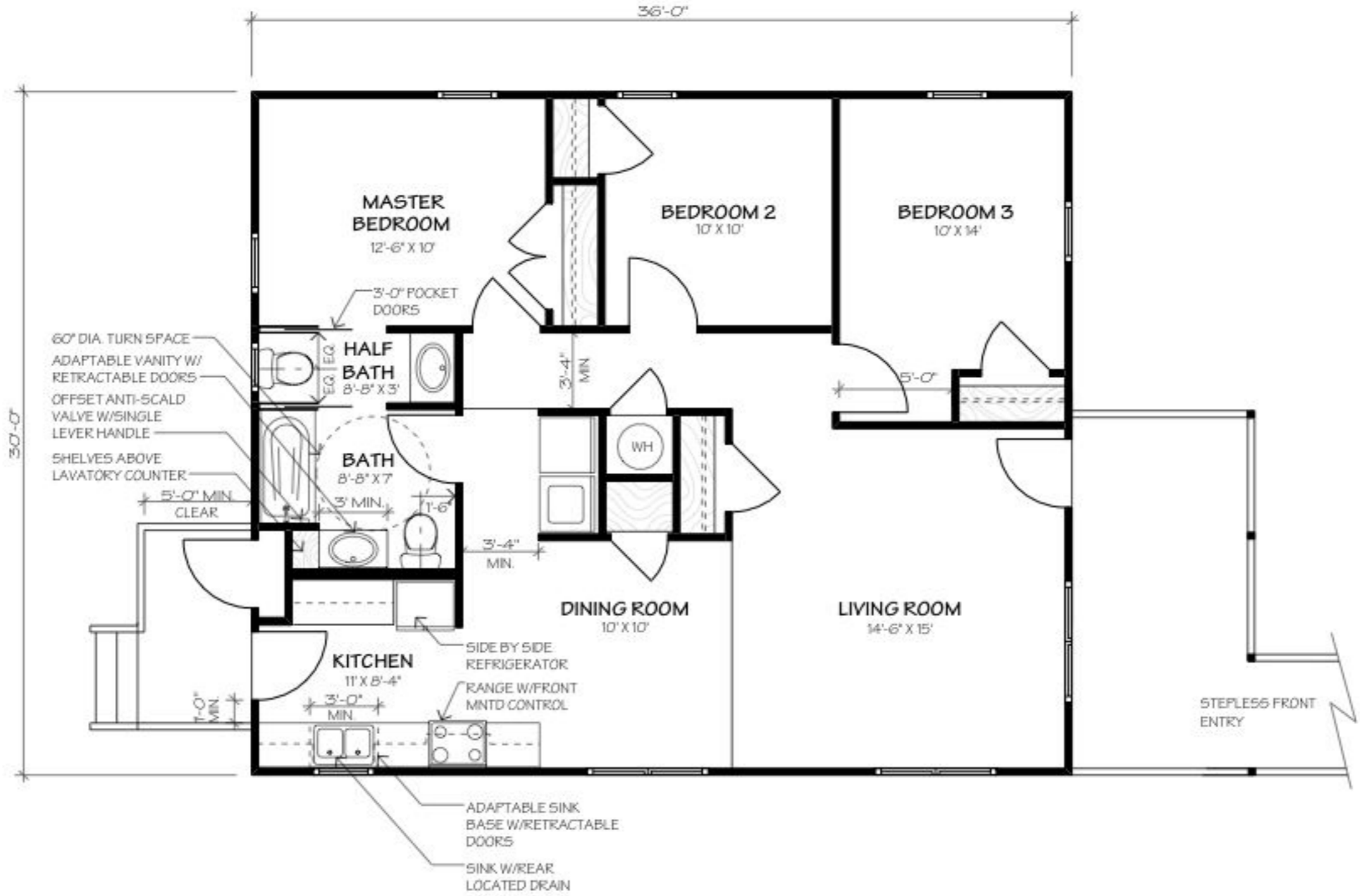

Disclaimer
These drawings are not for construction. If the information contained in these drawings is incorporated into any construction project, it shall be the responsibility of the owner, designer, or builder to comply with all applicable federal, state, and local codes, ordinances and regulations.

Title/Project: UNIVERSAL 3-BEDROOM PLAN "B"
Client: AFFORDABLE AND UNIVERSAL HOMES FOR INDEPENDENCE
Scale: 3/16" = 1'-0"
Date: 12/28/00

NOTES:

ROOM SIZES ARE APPROXIMATE.
 TOTAL AREA = 1080 SQ.FT.
 TYP STUD WALL THICKNESS = 3-1/2"
 ALL PASSAGE DOORS ARE 3'-0"
 ALL OTHER DOORS 3'-0" WHEN POSSIBLE.
 ENTRY CONFIGURATION DEPENDS ON UNIQUE SITE CONDITIONS

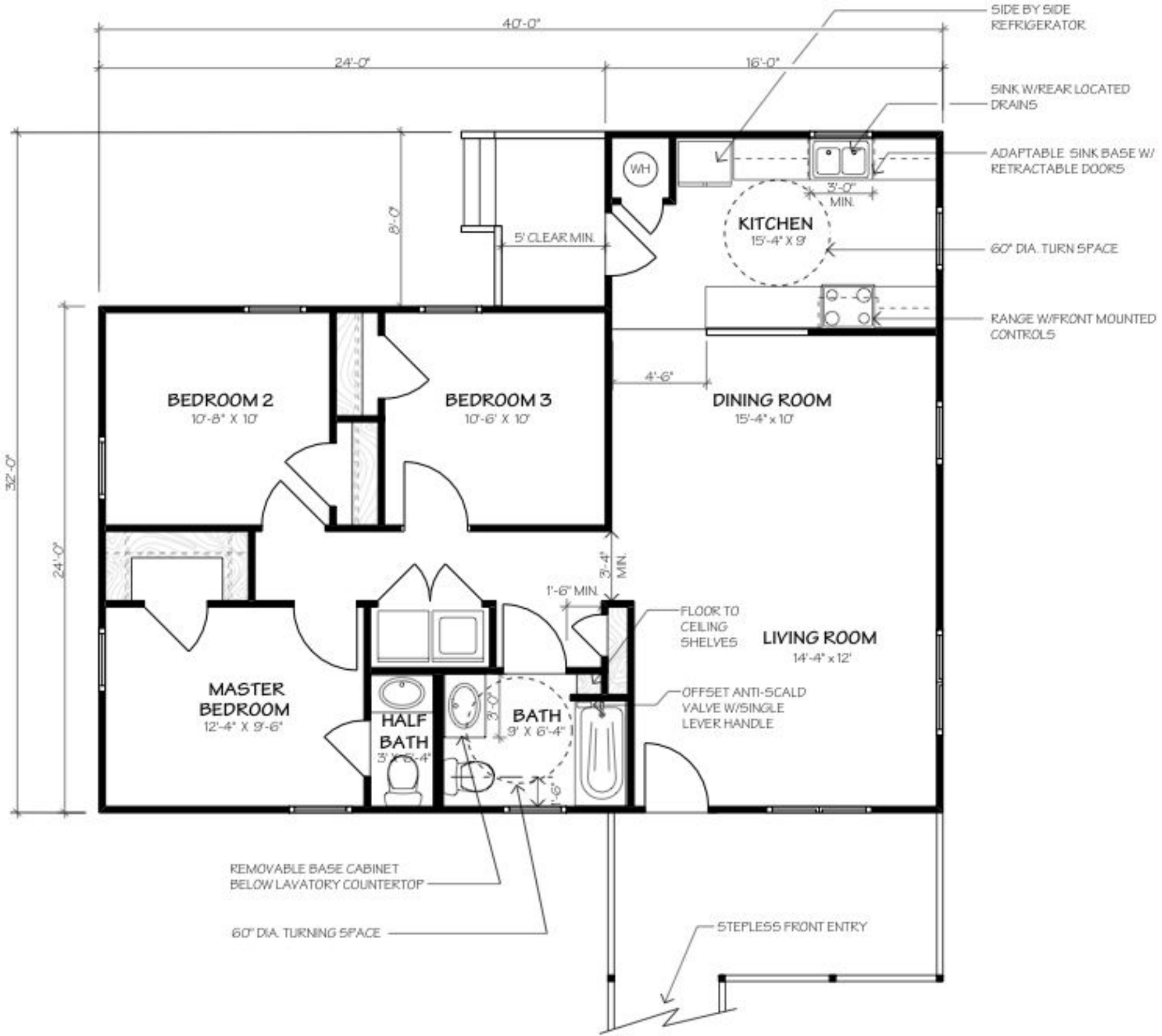

Disclaimer
 These drawings are not for construction. If the information contained in these drawings is incorporated into any construction project, it shall be the responsibility of the owner, designer, or builder to comply with all applicable federal, state, and local codes, ordinances and regulations.

Title/Project: UNIVERSAL 3-BERROOM PLAN "C"
Client: AFFORDABLE AND UNIVERSAL HOMES FOR INDEPENDENCE
Scale: 3/16" = 1'-0"
Date: 12/28/00

NOTES:

ROOM SIZES ARE APPROXIMATE.
 TOTAL AREA = 1288 SQ.FT.
 TYP STUD WALL THICKNESS = 3-1/2"
 ALL PASSAGE DOORS ARE 3'-0"
 ALL OTHER DOORS 3'-0" WHEN POSSIBLE.
 ENTRY CONFIGURATION DEPENDS ON UNIQUE SITE CONDITIONS

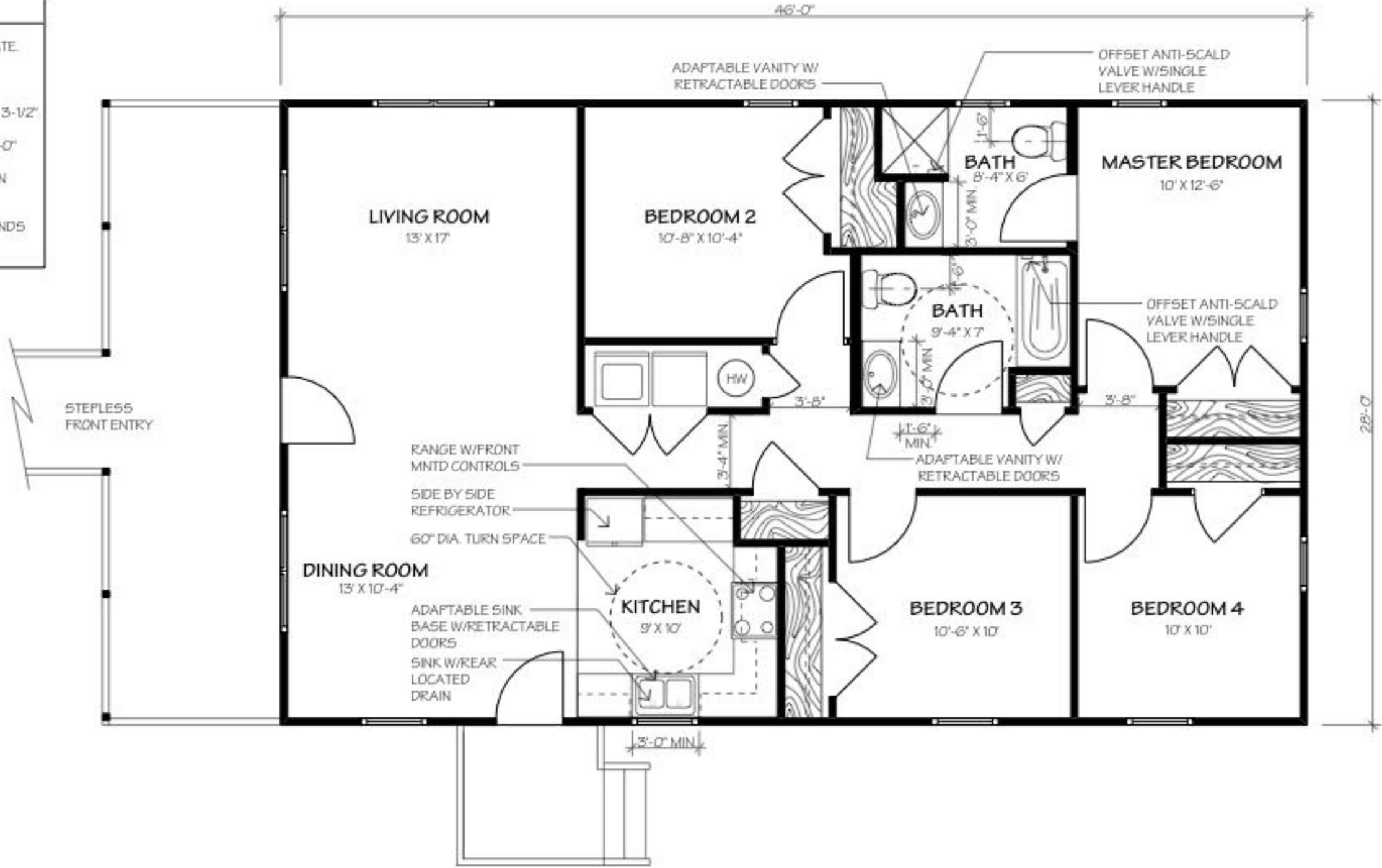

Disclaimer
 These drawings are not for construction. If the information contained in these drawings is incorporated into any construction project, it shall be the responsibility of the owner, designer, or builder to comply with all applicable federal, state, and local codes, ordinances and regulations.

Title/Project: UNIVERSAL 4-BEDROOM PLAN

Client: AFFORDABLE AND UNIVERSAL HOMES FOR INDEPENDENCE

Scale: 3/16" = 1'-0"

Date: 12/28/00

Examples of changes to an existing stock Habitat for Humanity floor plan. Revised floor plan shown is the Universal 3-Bedroom Plan C.



revisions



new universal plan



existing plan

Universal Design Features for Habitat for Humanity Homes

The following list of characteristics are elements, features, ideas or concepts that contribute to or can be components of a universal Habitat for Humanity house. This list is intended as a guide. Some are finite recommendations, some are options. Obviously, the more universal design characteristics or features included, the more usable the house.

of a universal house. Without them, no house can be considered universal. However, a house with only these three features is not universal either. A universal home begins with these three features and includes a variety of other convenience, safety, and ease of use features such as lowered light switches, reachable storage and electrical panel and others. The collection of these features combines to produce a universal home.

A stepless entry, wider doors and halls, and a usable bathroom are the essential components

ENTRANCES

Stepless Entrances

At least one stepless entrance by one of the following two methods:

- Earth berm and bridge and sloping walks at 1 in 20 maximum slope
- Site grading and earth work (with foundation waterproofing) and sloping walks at 1 in 20 maximum slope

NOTE: Avoid ramps. If ramps are inescapable, integrate into the design.

Other Entrance Features

- One-half inch maximum rise at entrance thresholds
 - View of callers for all people, including children and seated users through sidelights, windows in doors, and/or windows nearby
 - Weather protection shelter while unlocking and opening doors, such as porches, stoop with roof, awnings, or long roof overhangs.
- NOTE:** Decks/porches at these locations to be level with first floor
- Space at entry doors should be a minimum 5' x 5' level clear space inside and outside of entry door for maneuvering while opening or closing door.
 - Clear floor space (18" minimum) beside doors at latch jamb provides space to move out of the way of the door swing when pulling it open
 - Light for operating at entry doors: general illumination for seeing visitors at night

INTERIOR CIRCULATION

- At least one bedroom and accessible bathroom should be located on an accessible ground floor entry level (same level as kitchen, living room, etc.)
- 36" wide doors, for all doorways
- Clear floor space (18" minimum) beside door at latch jamb provides space to move out of the way of the door swing when pulling it open

Universal Design Features for Habitat for Humanity Homes

- Circulation route (40" minimum width) to provide maneuvering room in the hallways and archways
- An open plan design, minimizing hallways and doorways and maximizing sight lines

BATHROOMS

- Bathtub with clear floor space along its length, minimum 5' x 3' deep curbless shower, or 3' x 3' shower with a transfer seat
- Adequate maneuvering space: 60" diameter turning space in the room and 30" x 48" clear floor space at each fixture. Spaces may overlap
- Toilet located in 5' deep x 3' wide minimum (5' x 5' preferred) clear space with toilet centered 18" from any sidewall, cabinet, or tub
- Broad blocking in walls around toilet, tub, and shower allows for future placement and relocation of grab bars while assuring adequate load-bearing and eliminates the need to open up the wall to add blocking later
- Offset controls in tub/shower with adjacent clear floor space allows for easy access from outside the tub with no inconvenience when inside

FIXTURE CONTROLS

- Single-lever water controls at all plumbing fixtures and faucets
- Pressure balanced anti-scald valves at tubs and showers
- Hand-held showers

KITCHENS

- Space between face of cabinets and cabinets and walls should be 48" minimum with knee space or, a 5'-0" turning diameter
- Stretches of continuous counter tops for easy sliding of heavy items, particularly between refrigerator, sink, and stove top, for easy one-level food flow
- Full-extension, pull-out drawers, shelves, and racks in base cabinets for easy reach to all storage space
- Front mounted controls on appliances to facilitate easy reach
- Cook top or range with staggered burners and front or side mounted controls to eliminate dangerous reaching over hot burners
- Side-by-side refrigerator allows easy reach of otherwise hard-to-get items, particularly if pull-out shelving is provided
- Single-lever water controls at all plumbing fixtures and faucets

Universal Design Features for Habitat for Humanity Homes

LAUNDRY AREAS

- Front loading washers and dryers, with front controls, raised on platforms to reduce need to bend, stoop, or lean over

STORAGE

- Adjustable height closet rods and shelves allow for flexibility of storage options

CABINET/DOOR HARDWARE

- Easy to use, requiring little or no strength and flexibility:
 - lever door handles
 - loop handle pulls on drawers and cabinet doors-no knobs
 - touch latches
 - magnetic latches in lieu of mechanical, keyless locks

SWITCHES AND CONTROLS

- Light switches above floor, 42" - 48" maximum to center line, and thermostats at 48" maximum height to center line
- Easy-touch rocker switches
- Electrical outlets, 18" minimum height, allows easy reach from a sitting position as well as for those who have trouble bending over
- Electrical panel with top no more than 54" above floor located with a minimum 30" x 40" clear floor space in front

WINDOWS

- Windows for viewing, 36" maximum sill height

ADDITIONAL OPTIONS

KNEE SPACE

- Clear knee space under sinks (29" high minimum) with fold-back doors. Pipe protection panels prevent contact with hot or sharp surfaces.

SLIDING DOORS